

# キャッチパレットトラック 標準型 標準タイプ

メンテナンス不要の独創設計。画期的な搬送をお約束します。



ワンタッチのニュートラルレバー

DOWN



DOWN - 下降時  
UP - 上昇時  
N - ニュートラル  
負荷時でも軽々走行  
操作できます。

ノーバックング  
油圧ポンプ  
オリジナルの油圧機  
構です。

自動積荷  
チェックバルブ内蔵  
リフト時の過積載を  
防ぎ、作業者と製品  
を保護します。

バルブクリーニンク  
装置内蔵  
バルブ内を簡単に洗  
浄し、正常なバルブ  
状態を維持できます。



写真はCP-7M-85

すべての軸まわり  
にオイルレスプ  
ッシュ挿入



CP-15S-107

両面パレット用(1100mm)



CP-15L-140  
CP-20L-140

重量運搬専用型(5トン)



CP-50L-150

## 標準タイプ仕様

型式	仕様	最大 積載質量 (kg)	最低位 (mm)	最高位 (mm)	フォーク(mm)				全長 (mm)	全高 (mm)	ステアリング ホイール φ×幅 (mm)	ロード ホイール φ×幅 (mm)	車体 質量 (kg)		
					外幅	長さ								内幅	
CP-7M-85		700	65	185	450	850	788	840	210	1,206	1,150	ステレオ 150×45	ウレタン 65×56	51	
CP-7S-100	520				1,000	918	790	280	1,356						
CP-7L-100	650				1,200	1,118	990	410							1,556
CP-7L-120															
CP-10M-85		1,000	80	200	450	850	775	633	210	1,206	1,150	ステレオ 180×60	ウレタン 80×56	57	
CP-10S-100	520				1,000	925	783	280	1,356						
CP-10L-100	650				1,200	1,125	983	410							1,556
CP-10L-120															
CP-15M-85		1,500	80	200	470	850	727	569	170	1,230	1,170	ステレオ 180×70	ウレタン 80×73	64	
CP-15S-85									220						
CP-15S-98	520				980	857	699	1,360							
CP-15S-107					1,070	947	789	1,450							
CP-15S-115					1,150	1,027	869		1,530	1,170	ステレオ 180×70	ウレタン 80×73	75		
CP-15J-107	620	1,070	947	789	320	1,450									
CP-15L-85		850	727	569			1,230								
CP-15L-107					1,070	947	789	385	1,450	1,170	ステレオ 180×70	ウレタン 80×73	76		
CP-15L-122		1,220	1,097	939		1,600									
CP-15L-140		1,400	1,277	1,119		1,780									
CP-20S-85		2,000	80	200	520	850	727	569	220	1,230	1,170	ステレオ 180×70	ウレタン 80×73	74	
CP-20S-107					1,070	947	789	1,450							
CP-20S-115					1,150	1,027	869	1,530							
CP-20L-85					850	727	569	1,230	1,170						ステレオ 180×70
CP-20L-107		1,070	947	789	1,450										
CP-20L-122		1,220	1,097	939	1,600										
CP-20L-140		1,400	1,277	1,119	1,780				99						
CP-25S-107		2,500	80	200	520	1,070	947	789	220	1,450	1,170	ウレタン 180×70	ウレタン 80×73	86	
CP-25L-122					685	1,220	1,097	939	385						1,600
CP-30S-107					520	1,070	1,010	770	180						
CP-30L-122		3,000	85	205	685	1,220	1,160	920	345	1,990	1,170	ウレタン 180×70	ウレタン 80×73	105	
CP-30L-160					1,600	1,540	1,300		140						
CP-50L-150					1,500	1,440	1,200	360	1,900						1,190
CP-50L-180		5,000	100	220	700	1,800	1,760	1,500	360	2,200	1,190	ウレタン 200×70	ウレタン 80×73	240	

## 寸法図(標準タイプ)

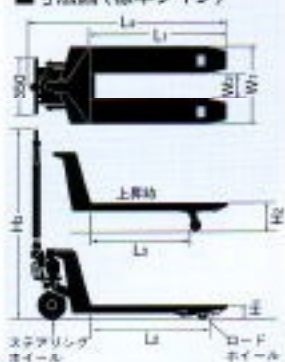

(オプション) W車輪型(標準タイプのみ)



CP-15,20,25



(オプション) パーキングブレーキ  
※全機種に取付けができます。



(オプション) 補助キャスター  
※重量運搬専用型(5トン)用

# Hand Pallet Truck further evolved

The comprehensive technology of OPK as a leading manufacturer has developed complete new models taking over the excellent performance of the long seller.

- ✓ Incorporates a resin-made handle.
- ✓ A variety of options to meet on-site needs.
- ✓ A completely new handle design.
- ✓ OPK's unique operation method.
- ✓ RoHS Compatible.
- ✓ Good Design Award from Japan.



Neutral lever operable at ease

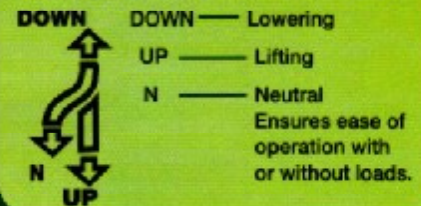

Incorporates automatic load check valve

Prevents pallet overloading at the time of lifting, thus protecting the operator and product.

Safety lowering valve

A built-in swoop prevention valve safely moves loads downward.

Incorporates valve cleaning device

Simply cleans the inner side of the valve, thus keeping the valve in normal condition

## Dimensions

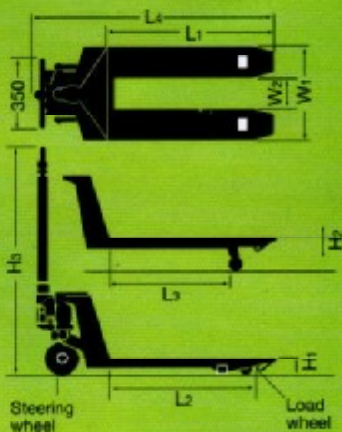

## Specifications for Standard Type

Specification Model	Capacity (kg)	Min. H (mm) H1	Max. H (mm) H2	Fork(mm)					Overall length (mm) L4	Overall height (mm) Hs	Steering wheel Dia. ø width (mm)	Load wheel Dia. ø width (mm)	Net weight (kg)
				Outer width W1	Length			Inner width W2					
					L1	L2	L3						
CP- 20S - 107 - M	2,000	80	200	520	1,070	950	790	220	1,480	1,170	Rubber	Urethane	74
CP- 20L - 122 - M				685	1,220	1,100	940	385	1,630		80 X 73	83	
CP- 25S - 107 - M	2,500	80	200	520	1,070	950	790	220	1,480	1,170	Urethane	Urethane	82
CP- 25L - 122 - M				685	1,220	1,100	940	385	1,630		80 X 73	88	
CP- 30S - 107 - M	3,000	85	205	520	1,070	1,010	770	180	1,480	1,170	Urethane	Urethane	100
CP- 30L - 122 - M				685	1,220	1,160	920	345	1,630		Tandem 80 X 73	115	

## Specifications for Low-Profile Type (65mm)

Specification Model	Capacity (kg)	Min. H (mm) H1	Max. H (mm) H2	Fork(mm)					Overall length (mm) L4	Overall height (mm) Hs	Steering wheel Dia. ø width (mm)	Load wheel Dia. ø width (mm)	Net weight (kg)
				Outer width W1	Length			Inner width W2					
					L1	L2	L3						
CP- 20S - 107H - M	2,000	65	185	520	1,070	940	790	220	1,480	1,170	Rubber	Urethane	74
CP- 20L - 122H - M				685	1,220	1,090	940	385	1,630		65 X 73	83	